

MANUEL D'INSTALLATION

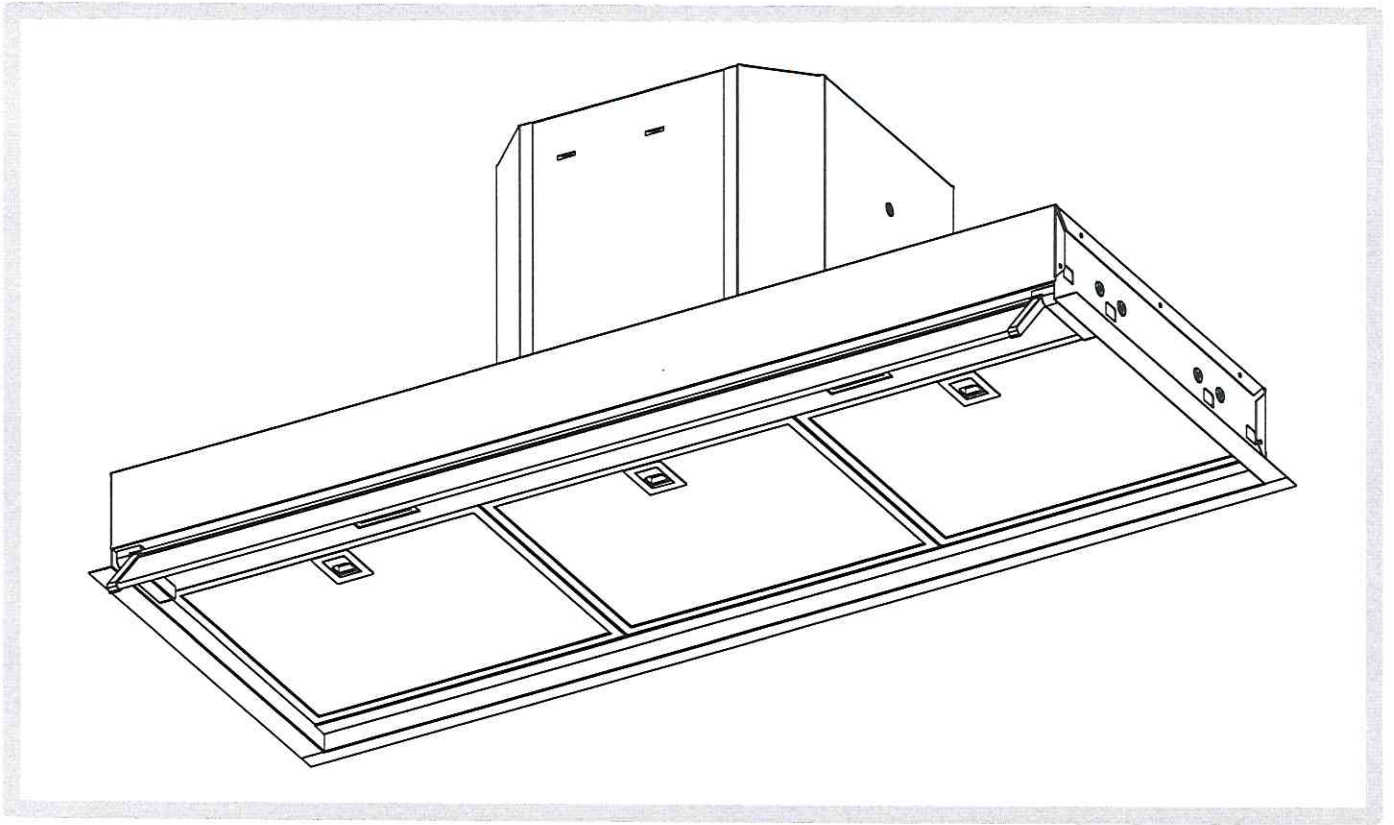

MELODIE INOX

FR Manuel d'installation
EN Installation manual
DE Installationsanleitung
IT Manuale per l'installazione
ES Manual de instalación
NL Installatiehandleiding

Hotte aspirante de cuisine
Kitchen extractor hood
Küchenabzugshaube
Cappa aspirante
Campana extractora
Afzuigkap voor de keuken



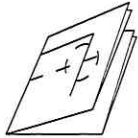

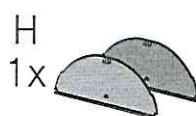
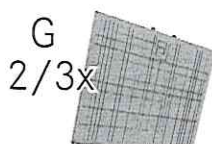
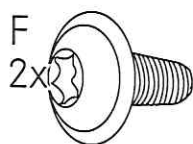
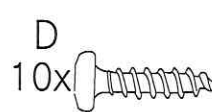
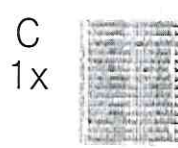
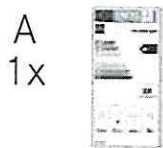

MELODIE INOX

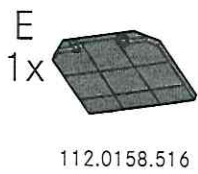
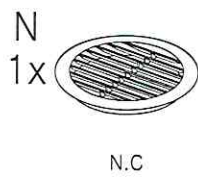
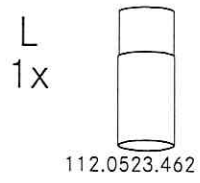
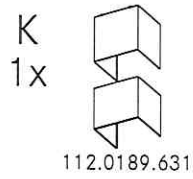
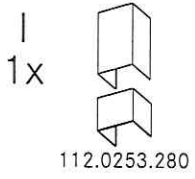

MELODIE INOX

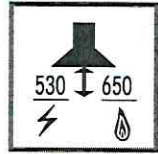

+

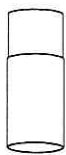
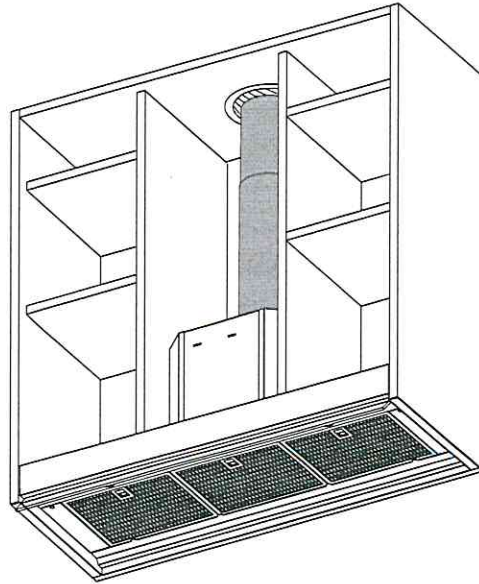

+

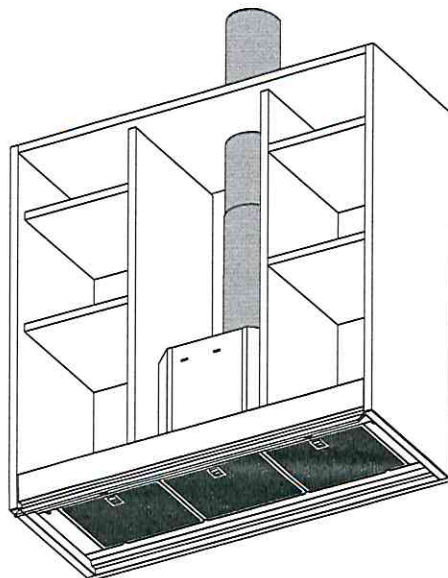
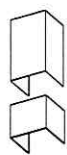

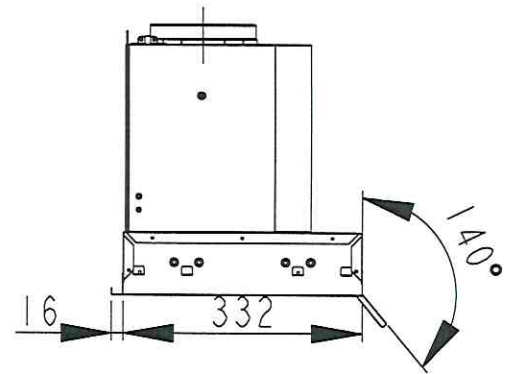
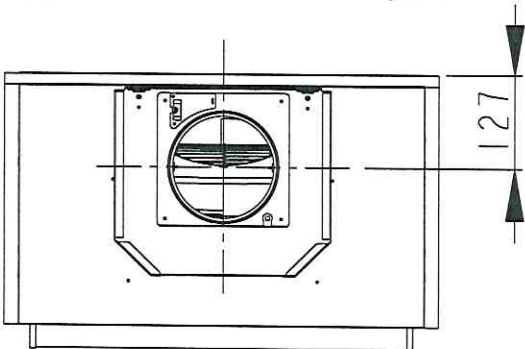
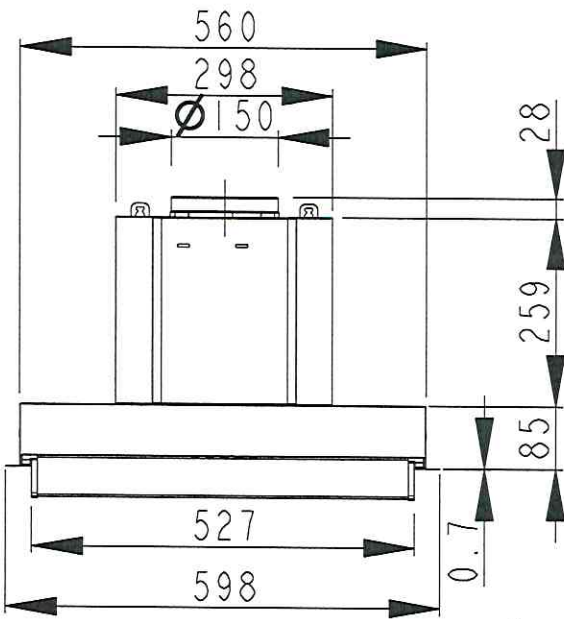
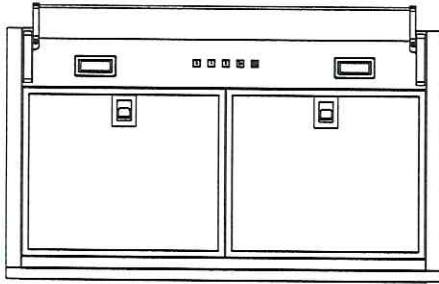
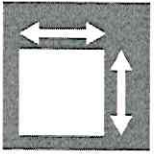

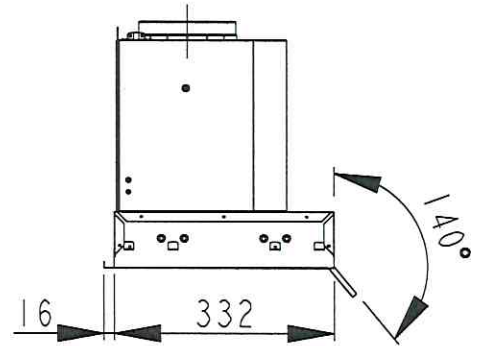
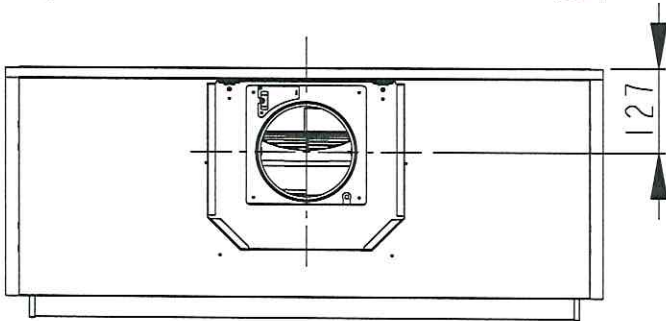
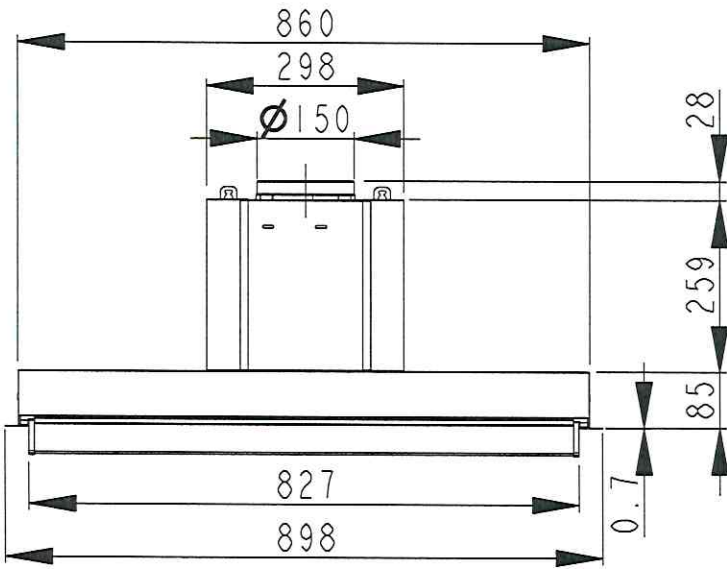
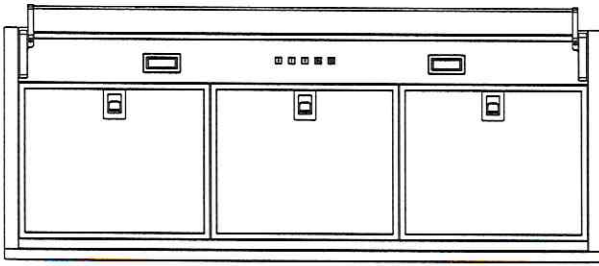
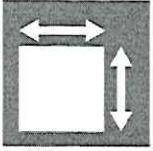

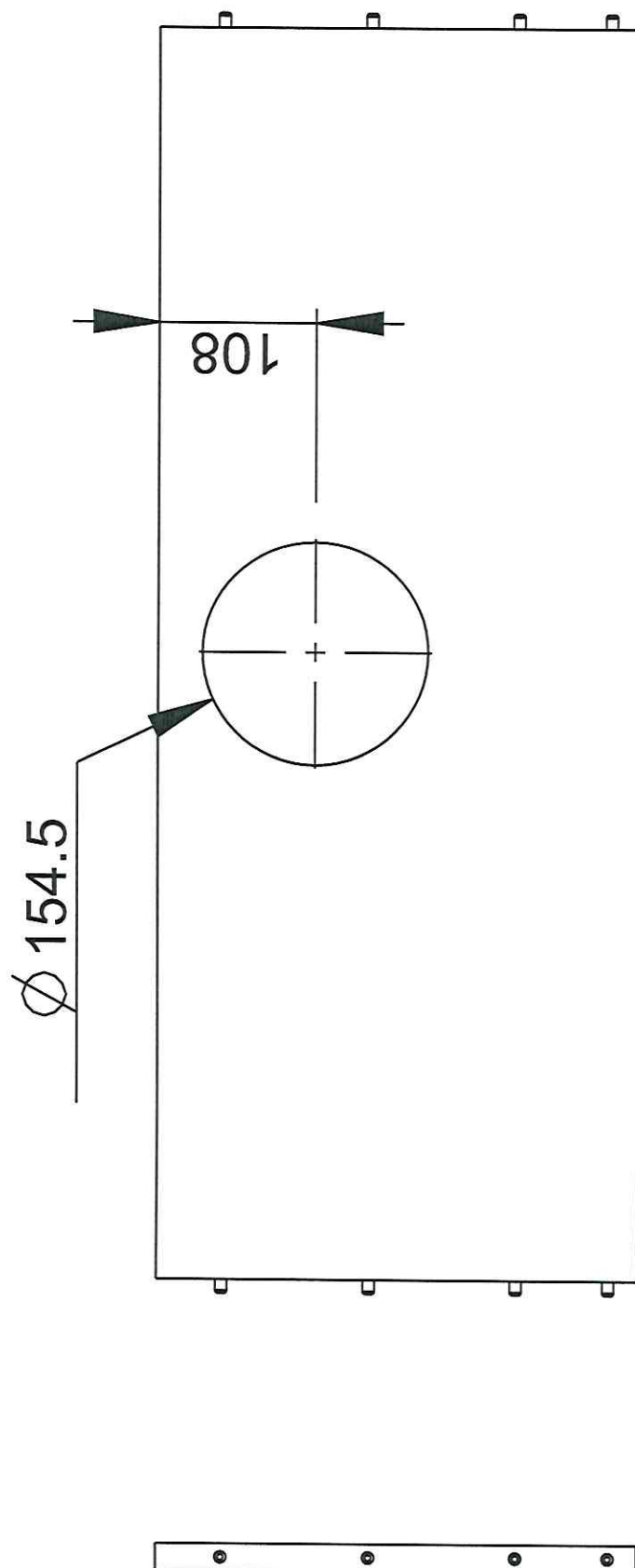
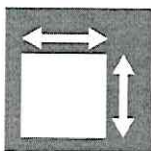

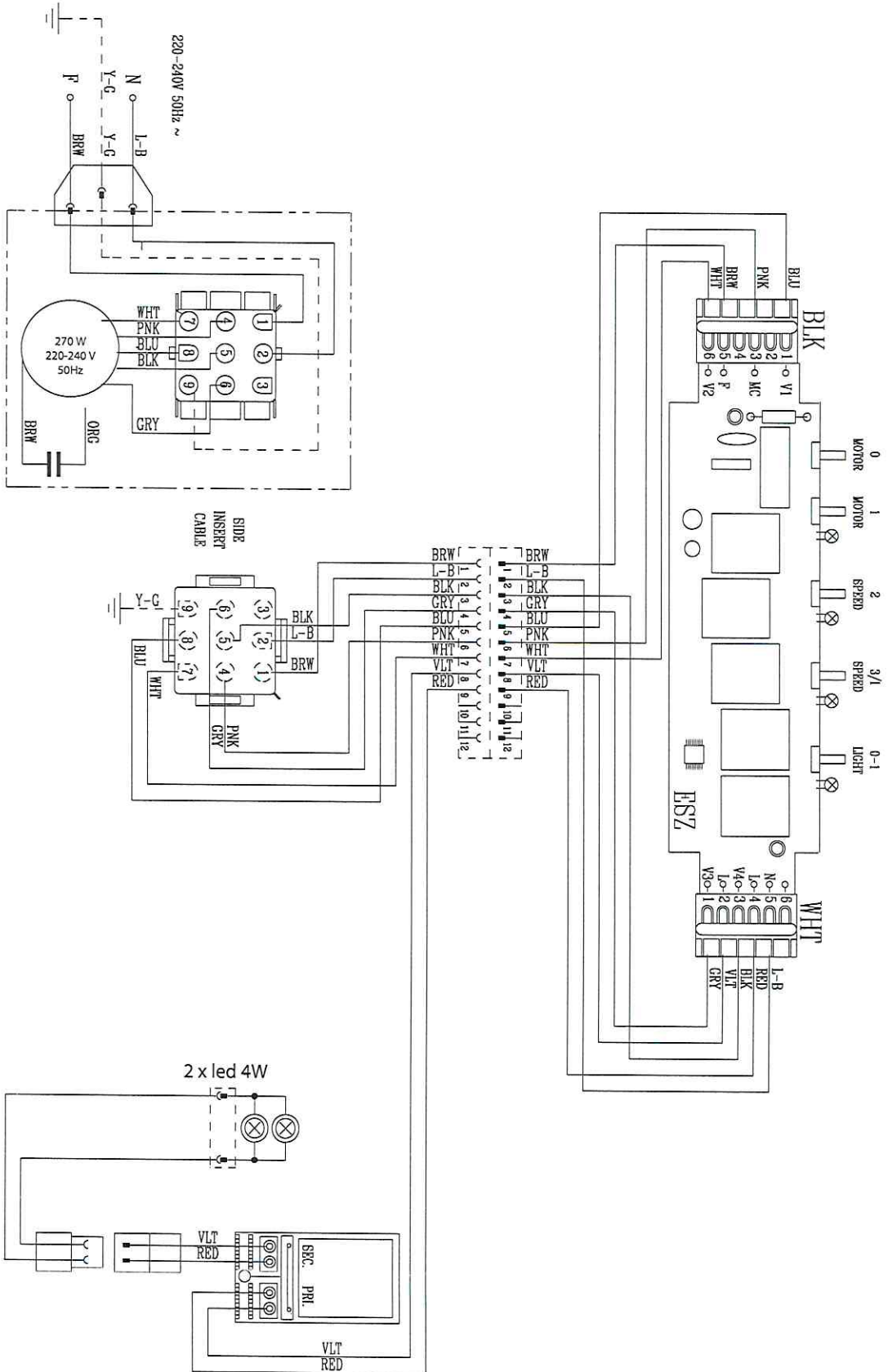
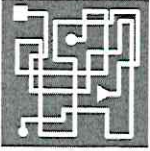

1

1

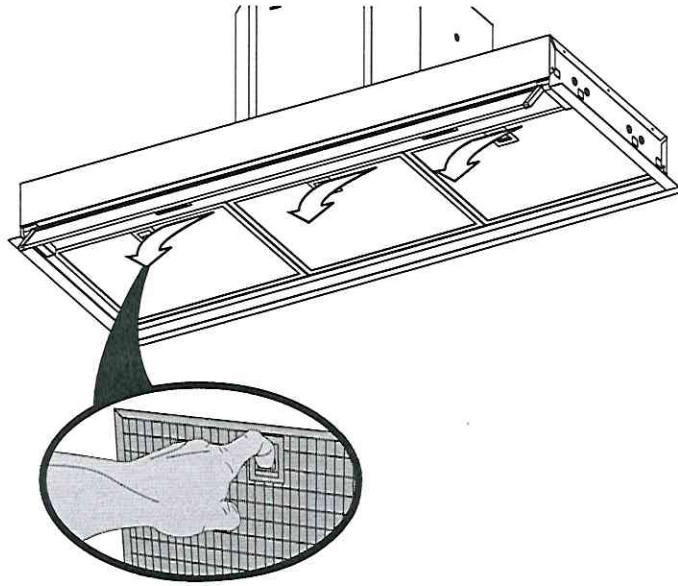

2

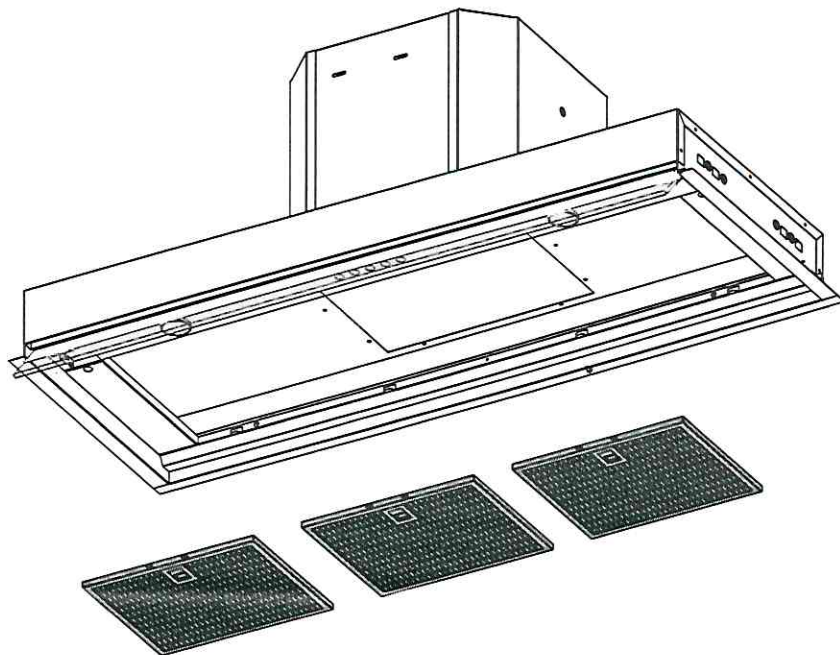

2

1

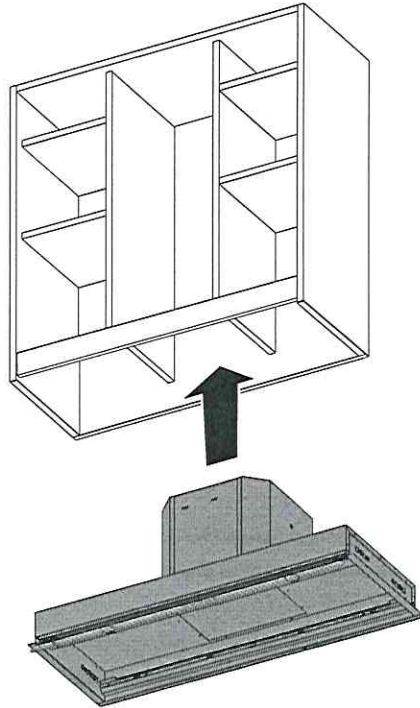

2

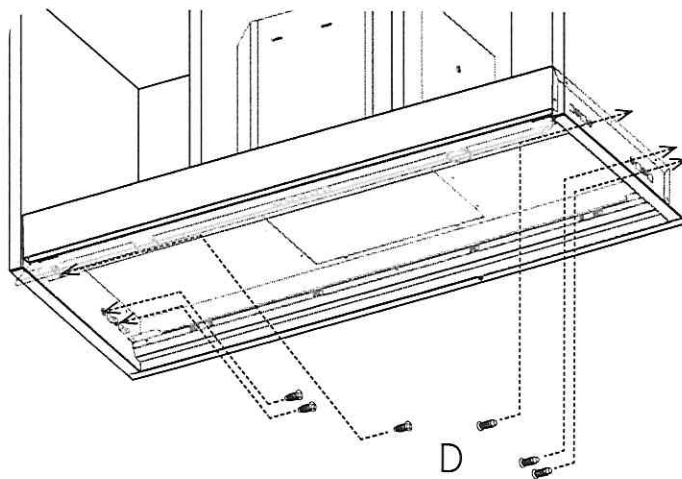

3



1

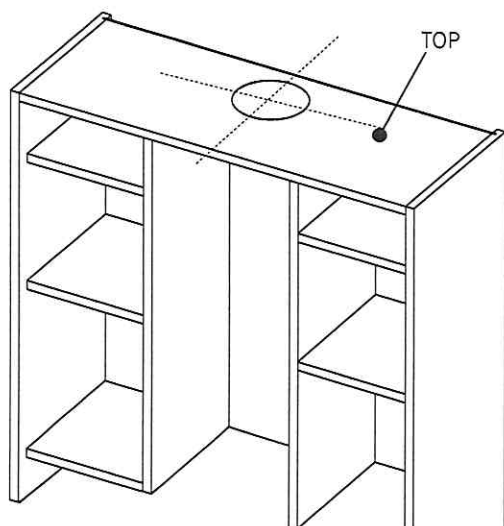

2

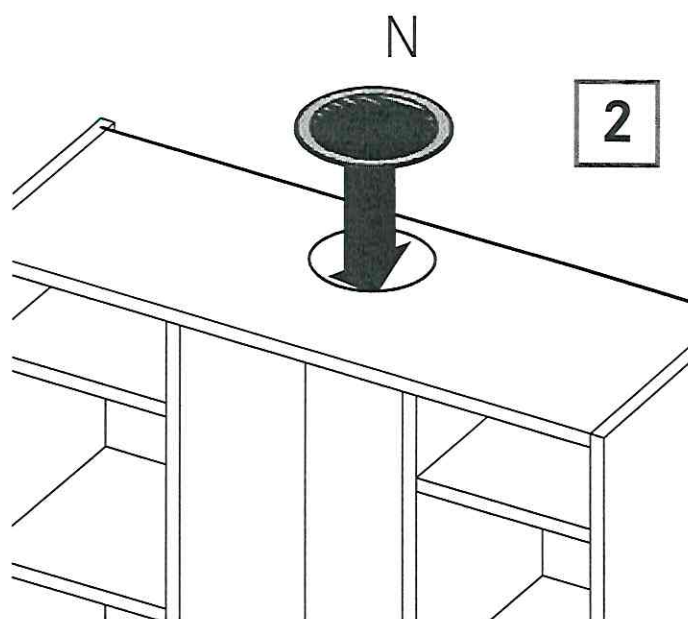

3

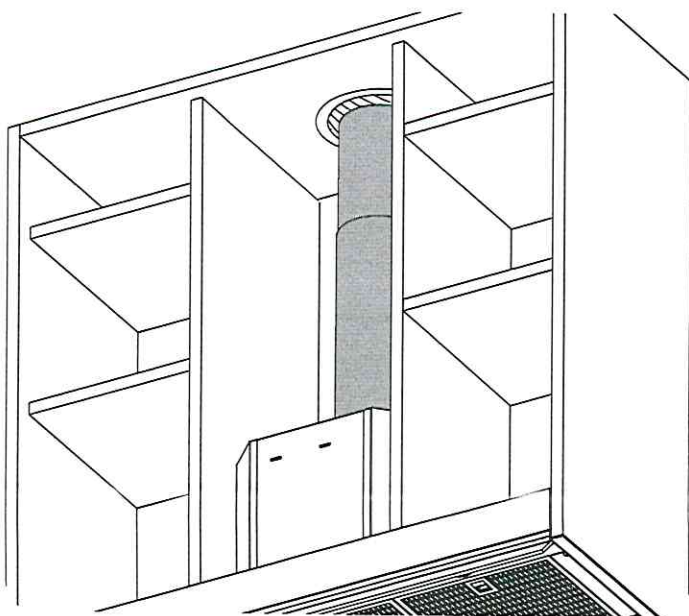

4



1

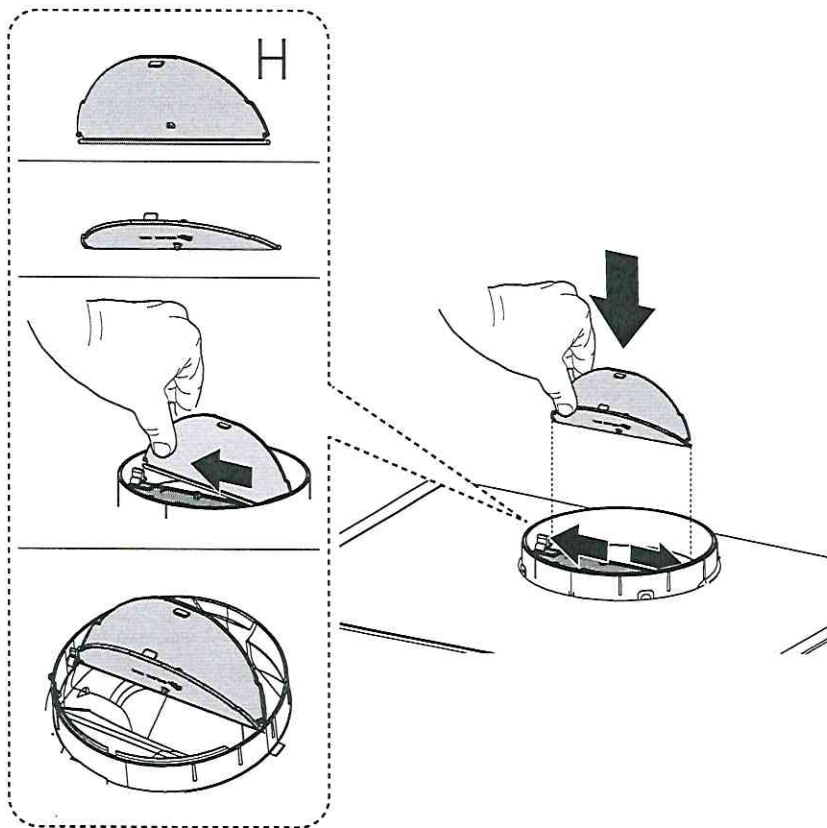

2

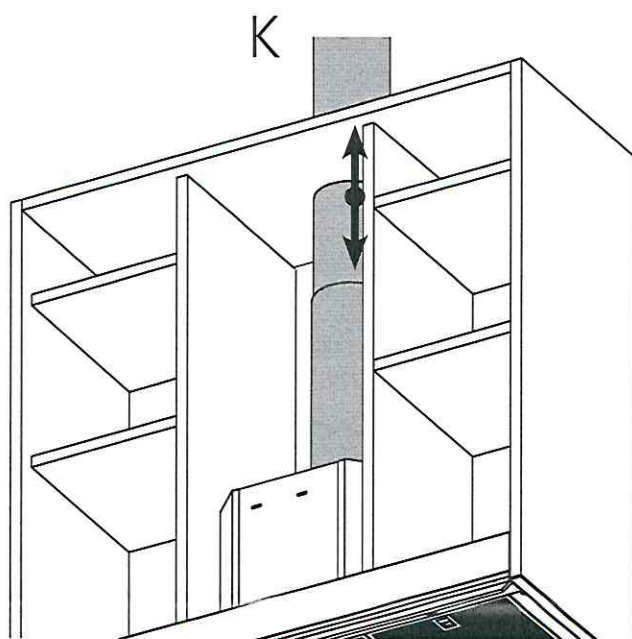

5

1

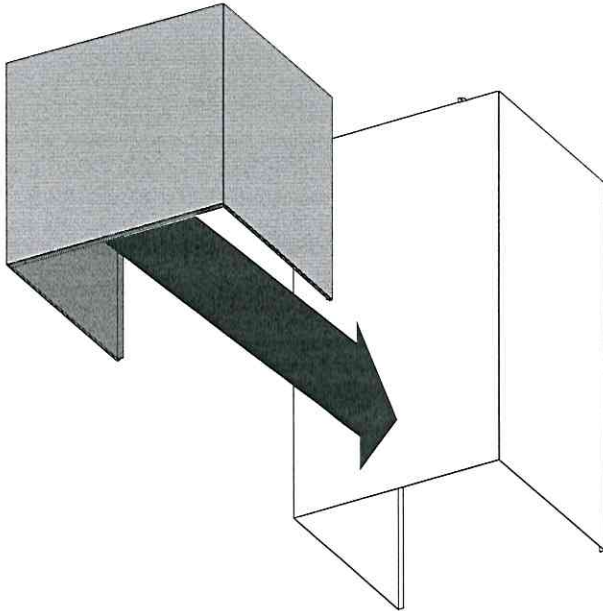

2

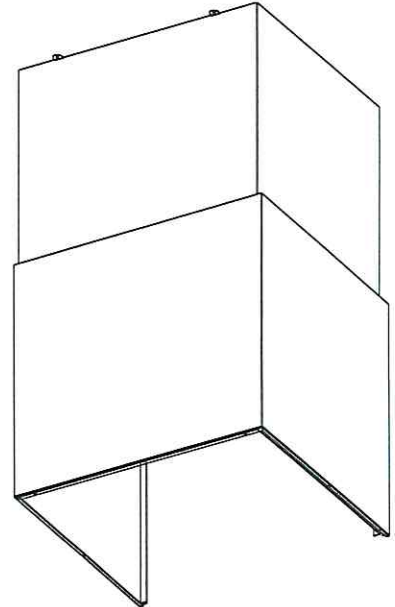

3

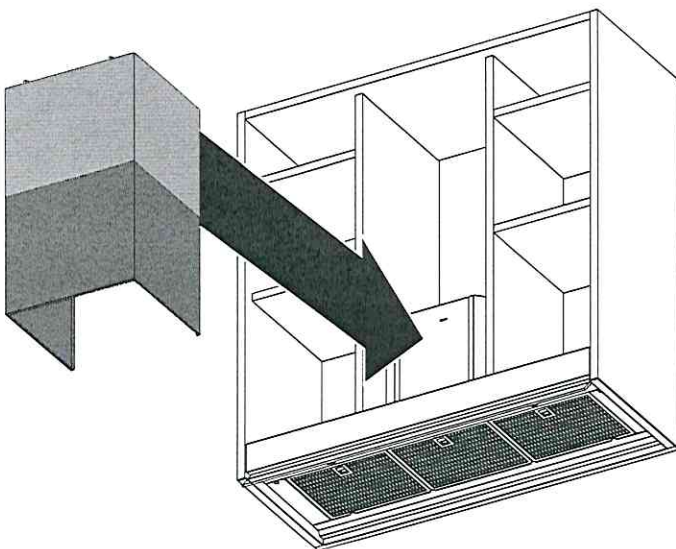

4

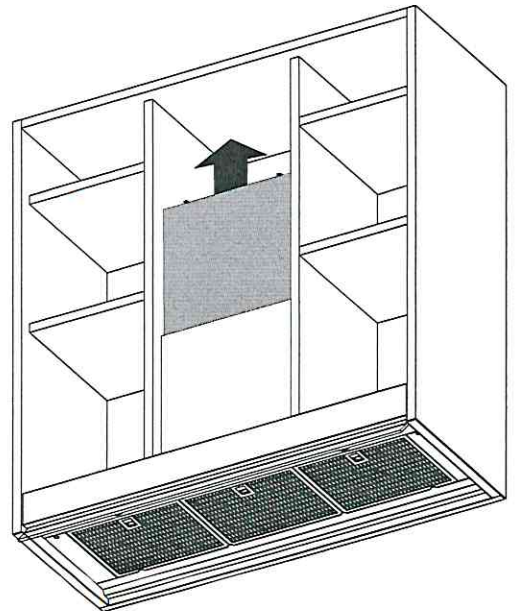

6

1

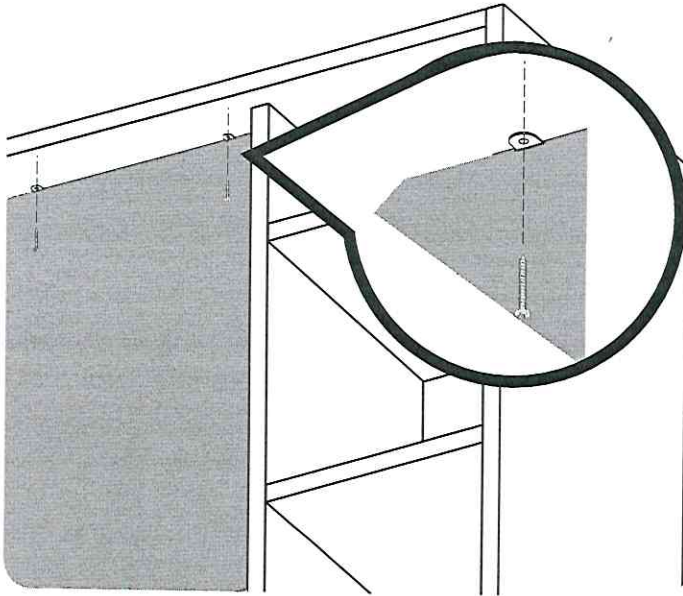

2

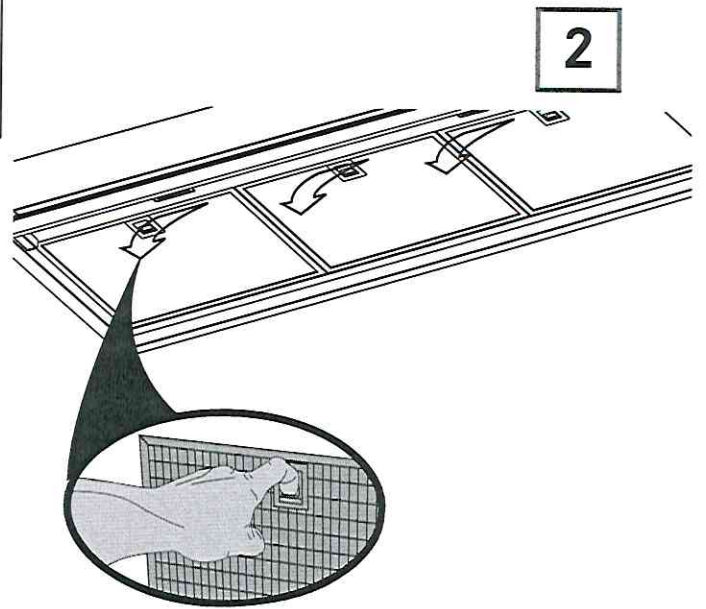

3

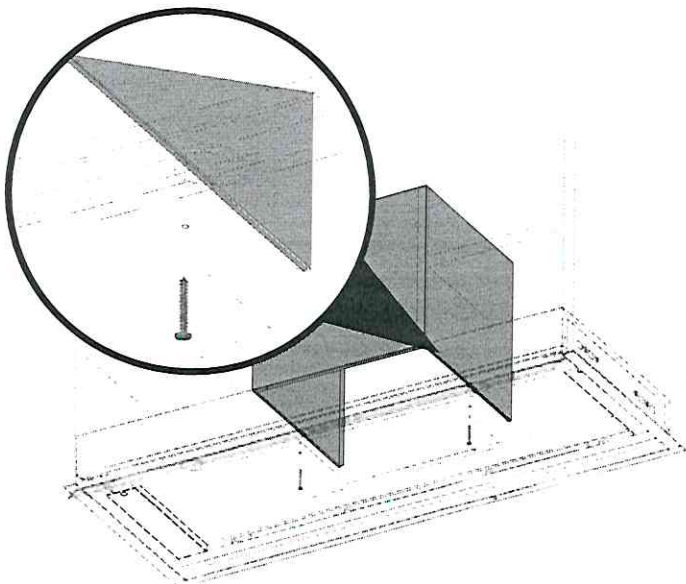

4

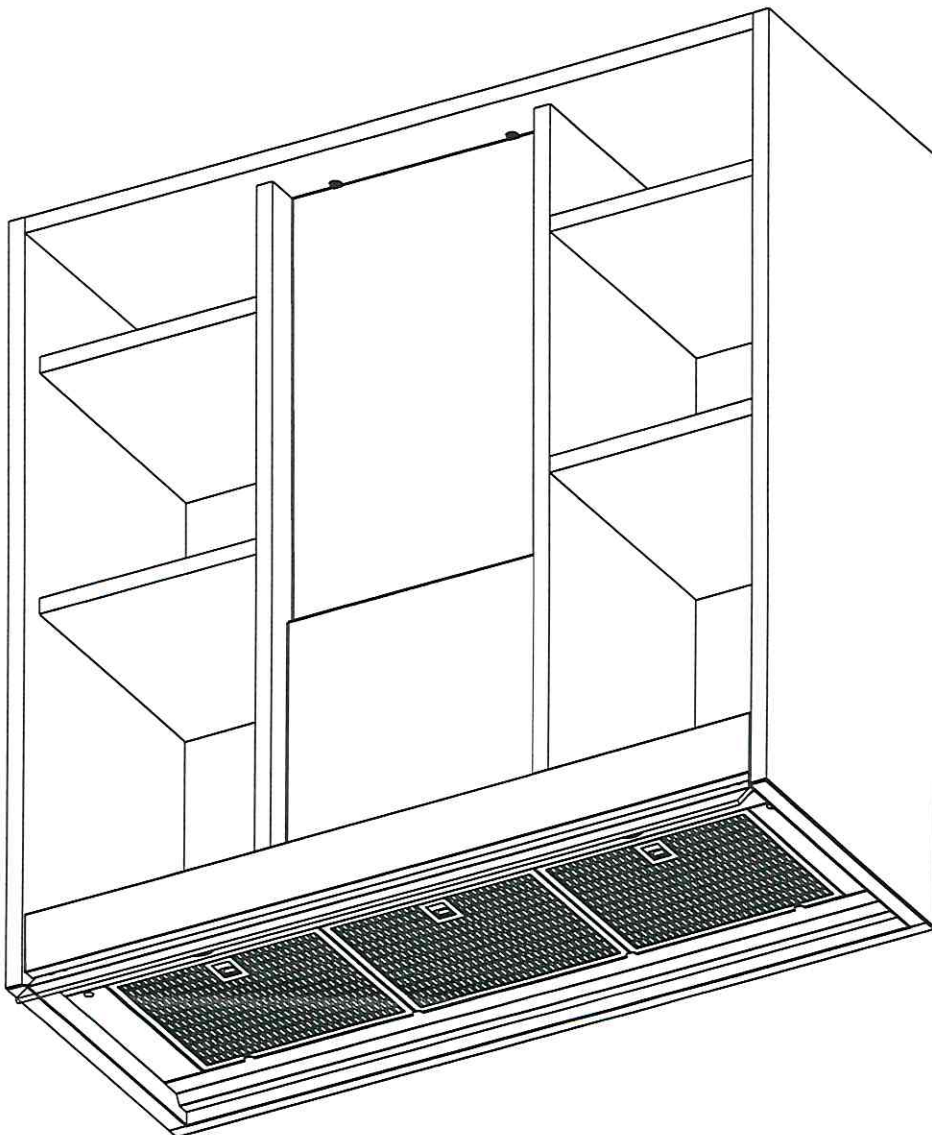
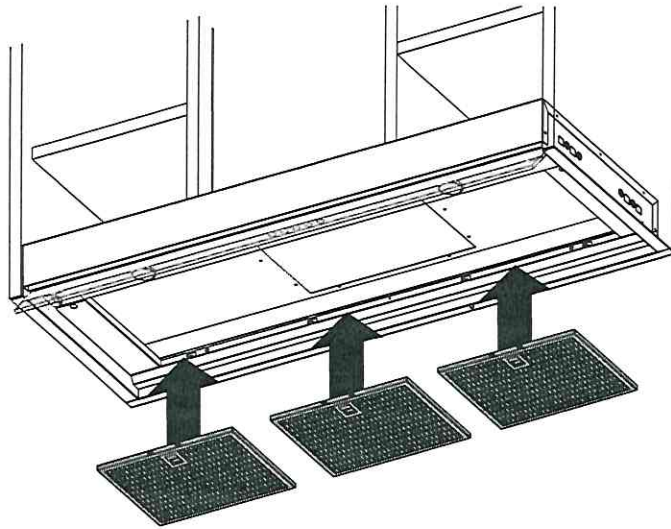

FR

Installation

- ▶ Assurez-vous que l'installation est effectuée uniquement par du personnel formé et qualifié.
- ▶ Durant l'installation, respectez les réglementations applicables concernant l'air évacué.
- ▶ Montez l'appareil avec du matériel de fixation adapté.
- ▶ Assurez-vous que les câbles endommagés sont remplacés par le fabricant ou le SAV.

Emplacement de montage

Assurez-vous que la cuisine dispose d'une ouverture vers l'extérieur pour garantir un échange d'air suffisant.

Si la hotte sert avec des appareils non électriques :

- ▶ Assurez-vous que la pression négative dans la pièce ne dépasse pas 0,04 bar pour garantir que les gaz évacués ne seront pas réaspirés.

Espacement

- ▶ Respectez la distance de sécurité entre le plan de cuisson et la hotte.

Si les instructions d'installation d'une gazinière requièrent une plus grande distance que celle indiquée dans ce manuel d'installation :

- ▶ Respectez les spécifications de la gazinière.

Raccordement de l'évacuation de fumée

- ▶ Ne connectez pas la hotte au conduit qui sert aux gaz de combustion (p. ex. venant d'une cheminée, d'un système de chauffage, etc.).
- ▶ Reliez la hotte à l'évacuation de fumée avec un conduit et assurez-vous que la longueur du conduit est aussi courte que possible.
- ▶ Si des appareils au gaz ou similaires, non électriques, servent dans la même pièce que la hotte : Assurez-vous que la ventilation est suffisante pour éviter le retour des gaz évacués.

Branchement électrique

- ▶ Respectez la tension d'alimentation (voir plaque constructeur).
- ▶ Pour les appareils de classe I : Assurez-vous que le réseau électrique du bâtiment est mis à la terre correctement.
- ▶ Reliez la hotte à l'alimentation électrique avec un commutateur disposant d'un écartement des contacts d'au moins 3 mm.

EN

Installation

- ▶ Make sure that the installation is carried out only by specifically trained and qualified personnel.
- ▶ During installation observe the applicable regulations concerning exhaust air.
- ▶ Mount the device only with suitable fixing material.
- ▶ Make sure that damaged cables are changed by the manufacturer or the customer service.

Mounting location

- ▶ Make sure that the kitchen has an opening to the outside to ensure a sufficient air exchange.

If the hood is used along with devices that do not require electricity:

- ▶ Make sure that the negative pressure in the room does not exceed 0.04 mbar to ensure that the exhaust gases will not be drawn in again.

Spacing

- ▶ Observe the safety distance between stove top and hood.

If the installation instructions for a gas-powered stove top require a greater distance than specified in these installation instructions:

- ▶ Observe the specifications of the gas-powered stove top.

Connecting the smoke vent

- ▶ Do not connect the hood to a shaft that is used for flue gas (e.g. from a fireplace, heating system etc.).
- ▶ Connect the hood to the smoke vent with a pipe and make sure that the route of the pipe is as short as possible.
- ▶ If gas-powered devices or similar devices that do not require electricity are used in the same room as the hood: Ensure a sufficient ventilation to avoid the backflow of exhaust gases.

Electrical connection

- ▶ Observe the supply voltage (see type plate).
- ▶ For devices of class I: Make sure that the power grid in the building is earthed correctly.
- ▶ Connect the hood to the mains power supply with a double-pole switch with a contact gap width of at least 3 mm.